

# 78017

Gamma detector



## GENERAL SPECIFICATIONS

<b>MAXIMUM LENGTH (INCH/MM)</b>	10.62/269.7
<b>MAXIMUM DIAMETER (INCH/MM)</b>	0.81/20.6
<b>GAS FILLING</b>	Ne +Halogen
<b>EFFECTIVE LENGTH (INCH/MM)</b>	9.51/241.6
<b>CATHODE MATERIAL (INTERNAL/EXTERNAL)</b>	446 Stainless Steel
<b>EFFECTIVE DIAMETER (INCH/MM)</b>	0.786/20.0
<b>CONNECTOR</b>	Flying Lead
<b>OPERATING TEMPERATURE RANGE °C</b>	-40 to +75

## ELECTRICAL SPECIFICATIONS

RECOMMENDED OPERATING VOLTAGE (VOLTS)	500
RECOMMENDED ANODE RESISTOR (MEG OHM)	3.3
OPERATING VOLTAGE RANGE (VOLTS)	450 - 650
MAXIMUM PLATEAU SLOPE (%/100 VOLTS)	10
MINIMUM DEAD TIME (MICRO SEC)	200
GAMMA SENSITIVITY CO60 (CPS/mR/HR)	160
TUBE CAPACITANCE (PF)	3
WEIGHT (GRAMS)	140
MAXIMUM BACKGROUND SHIELDED 50MM PB + 3MM AL (CPM)	90
MAXIMUM STARTING VOLTAGE (VOLTS)	400
MINIMUM ANODE RESISTOR (MEG OHM)	2.7

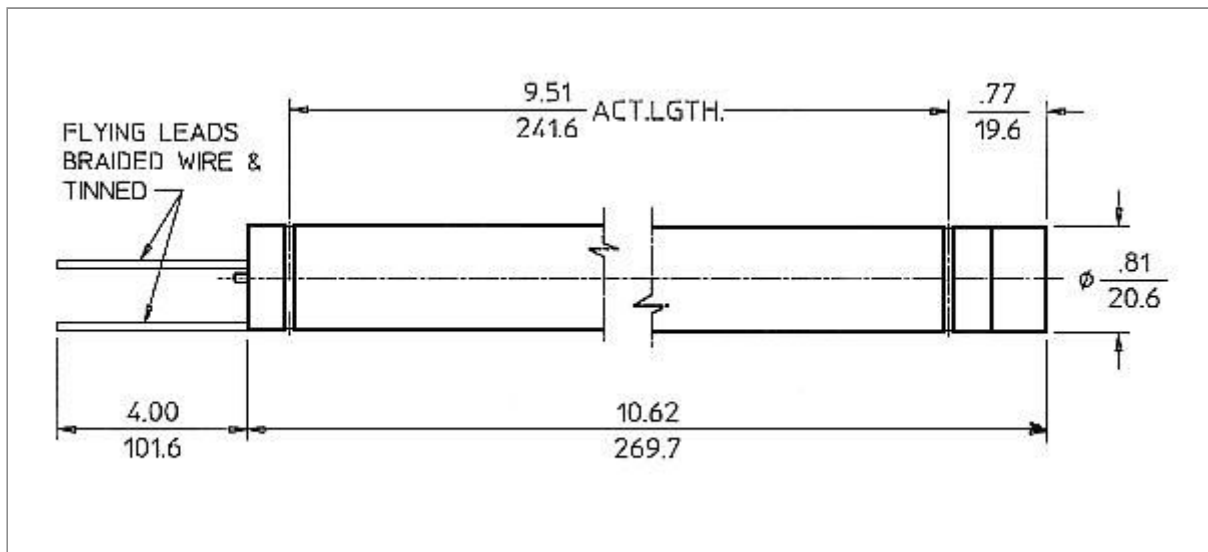

GAMMA SENSITIVITY

TUBE TYPE - 78017

